

# IOT Based Smart Grid Monitoring Using Arduino Controller

P.Shanmukha.V.Sai<sup>1</sup>, Y.Gopichand<sup>2</sup>, K.Manohar<sup>3</sup>, V.Nagamani<sup>4</sup>  
<sup>1,2,3,4</sup>UG Students, Tirumala Engineering College, Narasaraopet-522601, A.P, India.

**Abstract:** This project describes the digitization of load energy usage readings over the internet. The proposed system design eliminates the involvement of human in electricity maintenance. The user can monitor energy consumption in watts from a webpage by providing a channel id for the load. The Webpage utilizes the THINGSPEAK analytics to analyze the energy usage to give more detailed description and visualization of the energy usage statistics. Wi-Fi unit performs IOT operation by sending energy data of the load to the webpage which can be accessed through the channel id of the device. In the proposed system, consumer can do power management by knowing energy usage time to time. This proposed system utilizes an Arduino microcontroller. The unit which is generated can be displayed on the webpage through the Wi-Fi module.

**Keywords**— Current sensor, 16\*2 LCD Display, Arduino Nano Board, ESP 8266 Wi-Fi Module.

## 1. INTRODUCTION

The Internet of things (IOT) concept enables us to connect the normal day to day devices with each other over the internet. The devices connected through IOT concept can be analyzed remotely. The IOT concept provides the basic infrastructure and opportunities to form a connection between the physical world and computer based systems. The concept has been gaining importance with more and more wireless devices that are increasing rapidly in the market. Hardware devices are connected with each other over the internet. The ESP 8266 Wi-Fi module used in the system provides the connectivity with the internet in the system [1].

Now-a-days the demand for electricity is increasing at a constant rate in the population and is being utilized for various purposes viz., agriculture, industries, household purposes, hospitals etc.,. So, it is becoming more and more complicated to handle the electricity maintenance and requirements. Therefore there is an immediate requirement to save as much electricity as possible. As the demand from the newer generations of population for electricity is increasing so in along with it the technology improvement is needed. The proposed system provides a technical twist to the normal energy meters using the IOT technology. Also there are other issues that we have to address such as power theft which in turn generate economic loss to the nation. Monitoring, Optimized power usage and reduction of power wastage are the major objectives that lie ahead for a better system [3].

Smart energy meter using Wi-Fi system is designed based on three major objectives. They are:-

1. To provide automated load energy reading over an immediate basis.
2. To use the electricity in an optimized manner.
3. Reduce the power wastage.

The system basically can be classified on the basis of service ends in two ways:-

1. Consumer end
2. Service end.

The data from the system is displayed on a webpage which can be accessed by the consumer.

The system is designed on an Arduino micro controller [2]. It can be structurally differentiated into three parts viz., controller, theft detection circuit and a WiFi unit. The controller performs the basic calculations and processes the information. Theft detection circuit provides information about any extra or theft load energy reading and the most important role is played by the Wi-Fi unit to send the information from the controller over the Internet. The Arduino controller is programmed on the Arduino software IDE (Integrated Development Environment) which is a pre-requisite to operate on the Arduino board. Its code is derivative of the C language [4].

This paper describes Arduino Microcontroller based design and implementation of energy meter using IoT concept. The proposed system design eliminates the human involvement in Electricity maintenance. The Buyer needs to pay for the usage of electricity on schedule, in case that he couldn't pay, the electricity transmission can be turned off autonomously from the distant server. The user can monitor the energy consumption in units from a web page by providing device IP address. Theft detection unit connected to energy meter will notify company side when meter tampering occurs in energy meter and it will send theft detect information through PLC modem and theft detected will be displayed on the terminal window of the company side. Wi-Fi unit performs the IoT operation by sending energy meter data to web page which can be accessed through IP address.

## 2. BLOCK DETAILS

The smart electricity meter using Wi-Fi module can be easily described in two parts. The first part being the physical part and second one

being the Webpage, it consists of the Arduino Nano Board, ESP 8266 Wi-Fi module (Node MCU), 16\*2 LCD display, buzzer and power supply

### 3. BLOCK DIAGRAM

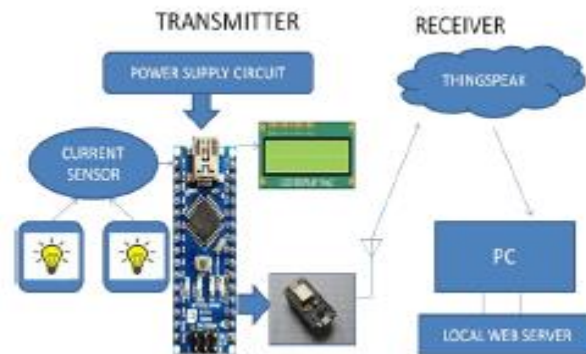

Fig -1: Block Diagram of the system

### 4. HARDWARE IMPLEMENTATIONS

A complete IoT based sensing system is proposed for Substation automation application in Smart Grid environment. Various parts of the system are discussed in detail along with their possibility of application alongside the present substation automation systems. An overall implementation of the system including network topologies, wireless communication networks and secure communication with other parts of the power grid is also discussed. The MQTT protocol suggested in the proposed system is relevant to the substation environment and provides a reliable and secure way to communicate sensor data to a large audience. The system design is cost effective and easy to implement and configure. It provides a new approach to monitor, store, visualize and communicate the sensor data using IoT in the substation environment. The proposed system is currently under implementation and an Arduino sensor node prototype has been tested as a part of it. Remaining implementation of the work is expected to be completed soon and presented in further research.

#### 4.1 Current Sensor

s.

The Allegro® ACS712 provides economical and precise solutions for AC or DC current sensing in industrial, commercial, and communications systems. The device package allows for easy implementation by the customer. The device is not intended for automotive applications.

The device consists of a precise, low-offset, linear Hall circuit with a copper conduction path located near the surface of the die. Applied current flowing through this copper conduction path generates a magnetic field which the Hall IC converts into a proportional voltage. Device accuracy is optimized through the close proximity of the magnetic signal to the Hall transducer. A precise, proportional voltage is provided by the low-offset, chopper-stabilized BiCMOS Hall IC, which is programmed for accuracy after packaging.

The output of the device has a positive slope ( $>V_{IOUT}(Q)$ ) when an increasing current flows through the primary copper conduction path (from pins 1 and 2, to pins 3 and 4), which is the path used for current sampling. The internal resistance of this conductive path is 1.2 mΩ typical, providing low power losses

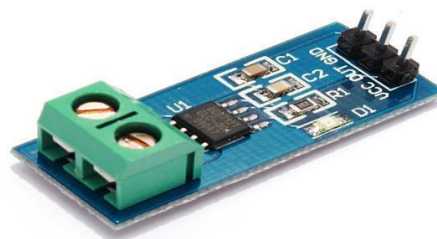

Fig -2: Current Sensor

#### 4.2 Arduino Nano Board

Arduino is a microcontroller board and it is based on the AT mega 328P. It consists of 14

digital I/O pins and 6 analog input pins and a crystal oscillator of 16 MHz frequency, a power supply jack and a USB port to dump the code,

ICSP header and a reset button. It can be powered with the power jack at the start and later can be

powered with AC to DC adapter or with a battery.

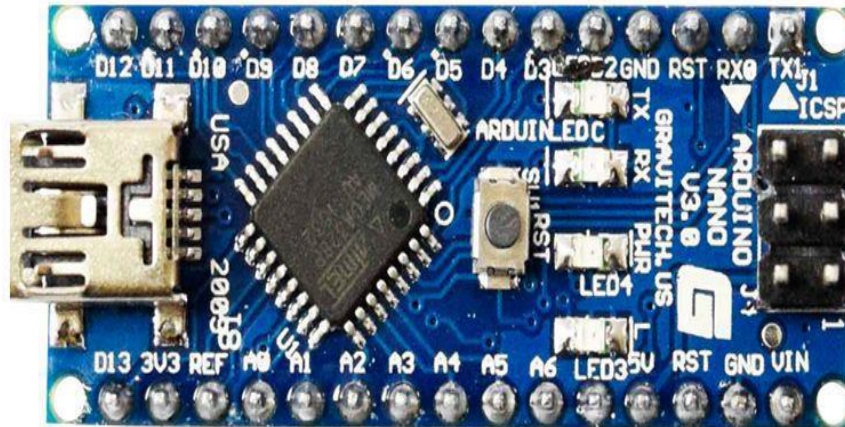

Fig -3: Arduino Nano board

#### 4.3 ESP 8266 Wi-Fi Module (Node MCU)

The ESP 8266 Wi-Fi module is a low cost component with which manufacturers are making wirelessly networkable microcontroller module. ESP 8266 WiFi module is a system-on-a-chip with capabilities for 2.4GHz range. It employs a 32 bit RISC CPU running at 80 MHz. It is based on the TCP/IP (Transfer control protocol) [3]. It is the

most important component in the system as it performs the IOT operation. It has 64 kb boot ROM, 64 kb instruction RAM, 96 kb data RAM.

Wi-Fi unit performs IOT operation by sending energy meter data to webpage which can be accessed through IP address. The TX, RX pins are connected to the 7 and 8 pins of the Arduino microcontroller



Fig -4: ESP 8266 Wi-Fi module (Node MCU)

#### 4.4 16\*2 LCD Display

LCD (Liquid crystal display) screen is an electronic display module and finds a wide range of applications. 16\*2 display means it can display 16 characters per line and there are 2 such lines. In this

LCD each character is displayed in 5\*7 pixel matrix.

The 11, 12, 13 and 14 pins of the display are used as data pins for Arduino interfacing. It is used to display the wattage.

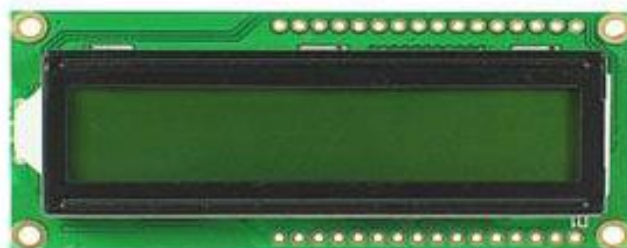
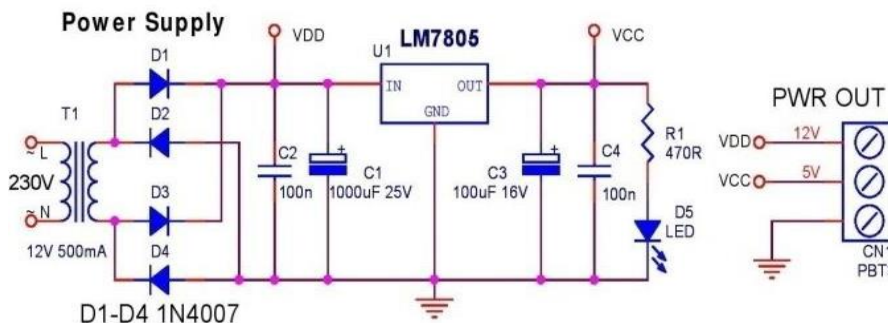

Fig -5: 16\*2 LCD display

**5. CIRCUIT DIAGRAM**

Two circuit diagrams have been used in the project. The circuit diagrams are as follows:-

**5.1 Power Supply Unit Circuit Diagram:**



**Fig -6: Power Supply Unit Circuit Diagram**

**5.2 Schematic Diagram:**

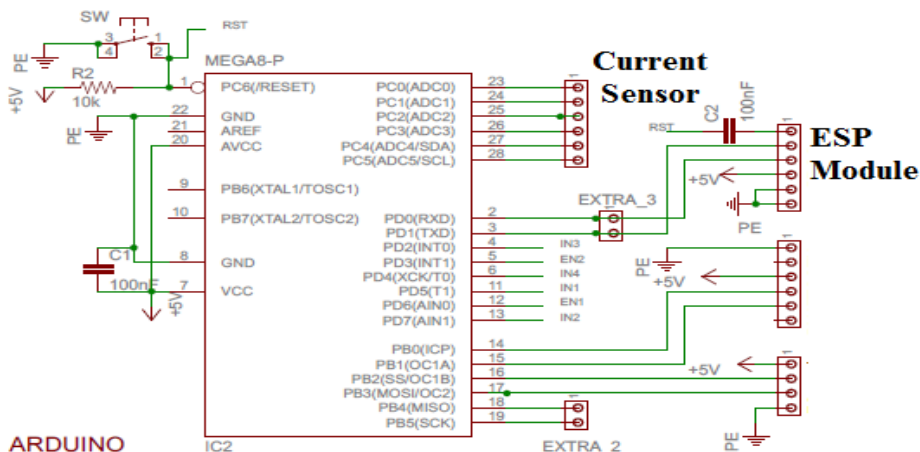

**Fig -7: Schematic Diagram**

**6. FLOW CHART**

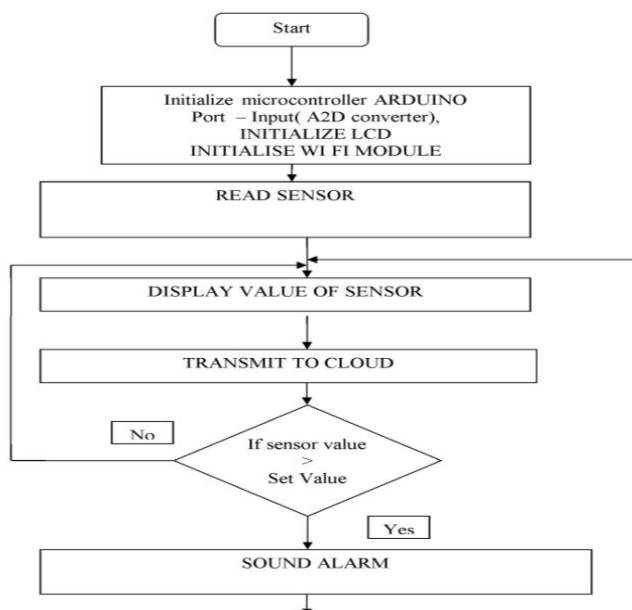

**Fig 8- Flow chart representation**



## 7. WEB PAGE

The proposed system can be used to display load energy usage reading in terms of Watts. Every user would be able to access the information from anywhere on the earth. Thingspeak.com is one such webpage which takes the help of the Math Works MATLAB analytics to present the device information in a more detailed analysis in both description and visualization. Thingspeak.com provides the user the ability to add any number of channels to one account and in each account information can be fed into 8 fields [7]. An account can be assigned to one division of an area and n channels can be created to a suite of n meters in the locality. The analytics can be viewed by both the consumer and service provider.

## 8. PROBLEM STATEMENT

The conventional methods which are in use today like SMS are costly. Since IOT is cost effective compared to SMS, monitoring of energy usage at lower cost is made possible. Daily consumption reports are generated which can be monitored by user through Android application and/or web portal. The system is more reliable and accurate reading values are collected from energy using devices. Live readings of devices can be viewed using Android application. Also, the readings can be viewed online. The human interference is avoided and all the values are kept maintained in the central server. The communication medium is secure and tampering of energy meters or theft of electricity can be identified easily. If an error occurs in the system, the value in the central server will not be updated. Since the values are stored in the central database, the reports are made accessible from anywhere in the world. Also, the server is online 24x 7 [4].

## 9. THINGSPEAK GRAPHIC INTERFACE

The Internet of Things provides access to a broad range of embedded devices and web services. ThingSpeak is an open data platform and API for the IoT that enables you to collect, store, analyze, visualize, and act on data from sensors or actuators, such as Arduino, BeagleBone Black, and other hardware. For example, with ThingSpeak you can create sensor-logging applications, location-tracking applications, and a social network of things with status updates, so that you could have your home thermostat control itself based on your current location. The primary element of ThingSpeak activity is the channel, which contains data fields, location fields, and a status field. After ThingSpeak channel is created, you can write data to the channel, process and view the data with MATLAB® code, and react to the data with tweets and other alerts. The typical ThingSpeak workflow lets you:

1. Create a Channel and collect data
2. Analyze and visualize the data

## 10. RESULT

Firstly we have to switch on the mains. Current sensor senses the power utilized by the load. Which gives output in analog form. The output of the sensor is supplied as input to the analog input part in the Arduino Nano Board. Arduino board has inbuilt analog to digital convertor which converts analog input of power to digital output. This digital output is displayed on LCD display in form of Watts as shown in Image -1 below. There is a set point value; when the power utilized by the load exceeds the set point value LCD displays “Theft detected” as shown in the Image -2 below.

The Node MCU is used to connect internet with the monitoring hardware system. The power utilized by the load is displayed in the cloud viz, ThingSpeak cloud in graphical format as shown in the Chart -1 and Chart -2 below. It shows time to time power utilization of the load/loads connected to the system.

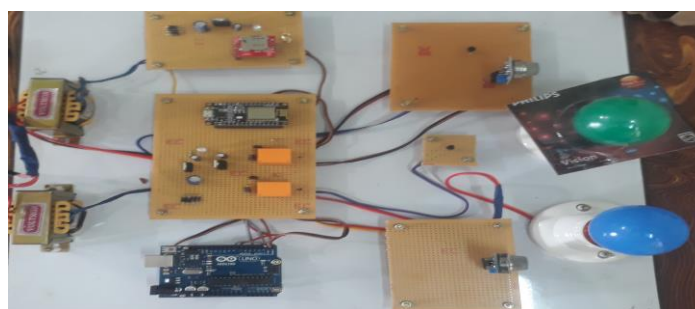

Fig 9. Proposed system Hardware view

## 11. CONCLUSIONS

Energy Monitoring using IOT is an innovative application of internet of things developed to

control home appliances remotely over the cloud from anywhere in the world. In the proposed project current sensor is used to sense the current

and display it on internet using IoT. The system updates the information in every 1 to 2 seconds on the internet using public cloud THINGSPEAK.

In the present system, energy load consumption is accessed using Wi-Fi and it will help consumers to avoid unwanted use of electricity. IoT system where a user can monitor energy consumption and pay the bill Online can be made. Also, a system where a user can receive SMS, when he/she crosses threshold of electricity usage slab can be equipped. We can make a system which can send SMS to the concerned meter reading man of that area when theft is detected at consumer end. Also using cloud analytics we can predict future energy consumptions.

#### **REFERENCES**

- [1] Landi, C.; Dipt. di Ing. dell'Inf., Seconda Univ. di Napoli, Aversa, Italy ; Merola, P. ; Ianniello, G, "ARM-based energy management system using smart meter and Web server", IEEE Instrumentation and Measurement Technology Conference Binjiang, pp. 1 – 5, May 2011
- [2] Garrab, A.; Bouallegue, A.; Ben Abdallah, "A new AMR approach for energy saving in Smart Grids using Smart Meter and partial Power Line Communication", IEEE First International Conference on Renewable Energies and Vehicular Technology (REVET), pp. 263 – 269, march 2012
- [3] Darshan Iyer N, Dr. KA Radhakrishnan Rao, "IoT Based Energy Meter Reading, Theft Detection & disconnection using PLC modem and Power optimization ",IRJET, (2015)
- [4] (2017 Jan. 31) ACS712 [Online] Available: <https://www.sparkfun.com/datasheets/BreakoutBoards/0712.pdf>
- [5] (2008 Oct. 29) Specifications of LCD [Online] Available: <https://www.sparkfun.com/datasheets/LCD/ADM1602K-NSW-FBS-3.3v.pdf>
- [6] (2013 April 15) ArduinoNano (V2.3) [Online] Available: <https://www.arduino.cc/en/uploads/Main/ArduinoNanoManual23.pdf>
- [7] (2014 March 19) ESP8266 Wi-Fi Module [Online] Available: [https://cdn-shop.adafruit.com/product-files/2471/0A-ESP8266\\_\\_Datasheet\\_\\_EN\\_v4.3.pdf](https://cdn-shop.adafruit.com/product-files/2471/0A-ESP8266__Datasheet__EN_v4.3.pdf)