

# Design and Implementation of Low Power LFSR for Fast ATPG Process

<sup>1</sup>Mr.N .Sai Ram, <sup>2</sup>Mr D.Saketh Samir, <sup>3</sup>Mr S.Sai Rishi, <sup>4</sup>Mr N.Sai Vamshi

Electronics And Communication Enginerring

Vignana Bharathi Institute Of Technology Hyderabad

sairam5724@gmail.com, dharanikotasaketh@gmail.com, rishisreepadha@gmail.com, Saivamsineralla@gmail.com

**Abstract**— In this paper, a new test pattern generation methodology is proposed to check the devices or circuits after manufacturing that takes advantage of shared memory multi- core systems which consumes less power and delay. Unlike the other test generation patterns this method generates the test patterns by Low Power LFSR using Gray code generator which consumes less power due to its less switching activity. This methodology is implemented in Half Adder and FIR filter circuits to check their functionality. This method is synthesized and simulated using Xilinx 14.7. The experimental results demonstrate that the proposed methodology achieves less power consumption and delay.

**Keywords**— ATPG, Low Power LFSR (Linear Feedback Shift Register), Gray Code generator, Memory multi-core, Half Adder and FIR filter.

## 1. INTRODUCTION

ATPG is an electronic design automation method/technology used to recognize whether the circuit is fault free or faulty. To verify the functionality of the circuit/device after manufacturing some test patterns are applied to the CUT. As the technology is shrinking in the IC manufacturing process multiple processing units (cores) are placed on a single chip as well as large amounts of on chip memory but these developments offer high processing power. While previously proposed procedures are very effective they are inherently non-parallel and thus, cannot perform automatic parallelization using sophisticated compilers. In the fault portioning is focused to increase the fault coverage. After that parallel ATPG has been proposed which uses on-chip multi-core era, but the ATPG components among multiple processing units are placed on the same chip . Next various parallel ATPG methods such as circular pipeline parallel ATPG and GPU based ATPGs are came into existence but they are having some disadvantages like same test sets are re-generating each time and limits the speed-up scalability. In this work we propose a parallel test pattern generation methodology which uses the shared- memory multi-core systems geared towards high speed. To generate the pseudo random test patterns Low Power LFSR is used which consumes less power and delay. In Low Power LFSR the patterns are in Gray code by which switching activity less compared to LFSR The rest of the paper is arranged as follows. Section 2 & 3 focuses on existing and proposed methods respectively. In section 4 and 5 proposed method is implemented on Half Adder and FIR filter circuits. Section 6 shows simulation and synthesis results while section 7 concludes the paper..

## 2. EXISTING METHODOLOGY

In existing method to check whether the device or circuit is working properly or not some of the test patterns are

applied to the CUT (Circuit Under Test) which are generated by LFSR which uses XOR operation. The block diagram of this methodology is shown below.

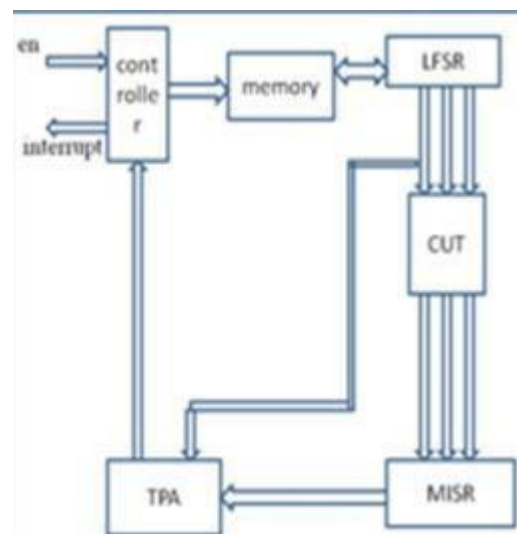

Figure 1: ATPG system on-chip circuit

The block diagram consists of following blocks such as LFSR, CUT, MISR, TPA, Controller and Memory.

### 2.1 Linear Feedback Shift Register

LFSR is used for generating the test patterns by which the functionality of the circuit is verified. It is a shift register whose input bits are operated by the XOR of some bits of the overall shift register value. The initial value which is given to the LFSR is called the seed.

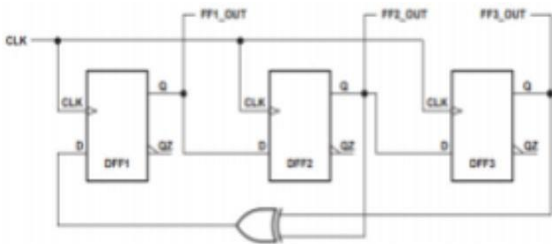

Figure 2: LFSR Circuit  
Exclusive-OR gate



A	B	Output
0	0	0
0	1	1
1	0	1
1	1	0

Figure 3: XOR Gate

**2.2 Circuit under Test**

The Circuit under Test is circuit or device which has to be tested. Buffer circuit is used in this existing method. The output of the Buffer circuit is same as the input.

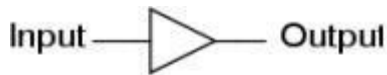

Input	Output
0	0
1	1

Figure 4: Buffer circuit

**2.3 Multiple Input Shift Register**

The Multiple Input Shift Register is used in an output section; the existing output of the circuit/device is to be compared with fault free output for detection of error. It contains all D flipflops whose output is feed backed to the input and then bits will be shifted. This shifted output patterns are compared with the output patterns of LFSR to check whether circuit is faulty or not. If CUT has any type of error the MISR patterns does not match with the LFSR patterns. This is because if CUT does not work properly it does not give correct output to the MISR, by that the MISR patterns also have some errors.

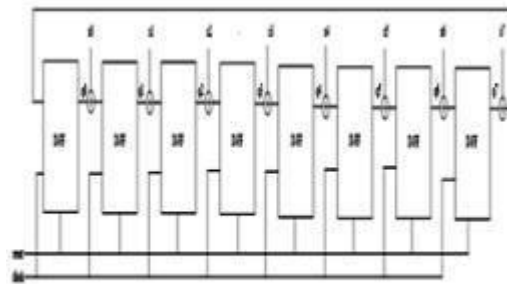

Figure 5: Multiple Input Signature Register

**2.4 Test Pattern Analyzer**

The Test Pattern Analyzer compares the output patterns of LFSR and MISR and gives the output to controller.

**2.5 Controller**

The controller has one input as enable and one output as interrupt. When enable is high then only the whole process of the ATPG is started. If the output patterns of LFSR and output patterns of MISR are not same then the interrupt will be 1 otherwise 0.

**2.6 Memory**

The ATPG system uses the concept of memory multi-core which is used to store the pseudo random test patterns by the speed of the process increases. The memory multi-core is divided into multi-cores i.e., two multi-cores in which the LFSR test patterns are stored in memory. As the number of cores increases the speed also increases.

**3. PROPOSED METHODOLOGY**

Now-a-days the desire for the portable devices is increasing enormously. So the Power reduction is necessary to satisfy the demands of the consumer. The test patterns generated using LFSR finds complexity in Power. For the purpose of power reduction the patterns are generated using Low Power LFSR which uses Gray code rather than binary code. The purpose of choosing gray code is to reduce the power requirements. In proposed methodology Low Power LFSR is used for the generation of the test patterns using Gray code Generator which consumes less power and delay. The Low power LFSR is similar to the LFSR but the initial seed is converted into Gray code using Gray code generator. After that, rest of the patterns is generated using XOR operation. This method reduces power consumption and delay up to 55% and 6% respectively.

**3.1 Low Power LFSR**

In ATPG to verify the functionality of the circuit some of the test patterns are applied to the CUT (Circuit Under Test). This Low Power Linear Feedback Shift Register is used to generate the test patterns with less power consumption and delay. Normally LFSR is used to generate the test patterns but they consume high power. So the Low Power LFSR method is proposed to reduce the power consumption and delay. The LFSR is a shift register whose input bit is a linear function of its previous state. Thus, an LFSR is a shift register whose input bit is operated by the XOR gate and after that the output is feedback to the input. The initial value of the LFSR is called the seed. This LFSR consumes high power. The

Low Power LFSR is same as the normal LFSR but it uses gray code generator by which the initial seed is converted from binary code to gray code, after that rest of the patterns are generated using XOR operation. The switching activity in gray code is less compared to the binary code. So the Low Power LFSR consumes less power. Low Power LFSR generated patterns are in Gray code which has less switching activity compared to the binary code. As the switching activity is less, the glitches, noise, power consumption and delay are also less compared to the binary code. The Gray code generator is used to convert binary code into gray code. The Low Power LFSR block is shown in fig. 6.

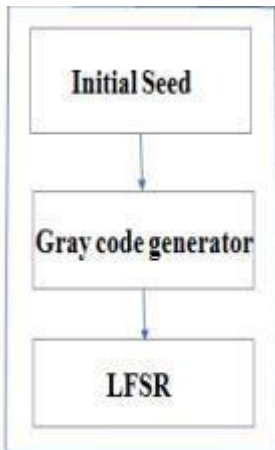

Figure 6: Low Power LFSR

3.2 Binary to Gray Code Conversion

It is a very simple process which includes various steps for the conversions. By observing below steps we can get a clear idea about this conversion.

- (1) Firstly the M.S.B. of the gray code should be exactly equal to the 1st bit of that binary number.
- (2) Next the 2nd bit of the code is exclusive-or of the
- (3) 1st and 2nd bits of that binary number, i.e. the result should be 0 when both the bits are same and otherwise the result will be 1.
- (4) The 3rd bit of that gray code is equal to the

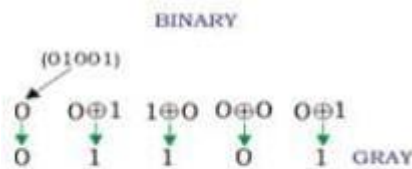

Figure 7: Binary to gray conversion

exclusive-or of the 2nd and 3rd bit of that binary number. Like this the process of the Binary to gray code conversion continues. An example of Binary to Gray conversion is shown below.

Hence the equivalent gray code of that binary code is 01101. Now see the example where the M.S.B. bit of the binary is 0 so the M.S.B bit for gray code is also 0. Next, the XOR of the 1st and 2nd bit is 1 because both the bits are different. Again go to the next step where

the XOR of 2nd and 3rd bit is again 1 because they are different. Next, XOR of 3rd and 4th bit is 0 because both the bits are equal. Finally the XOR of 4th and 5th bit is 1 because they are different. Like this the gray code conversion of 01001 is 01101. The block diagram of proposed methodology is shown in fig.8.

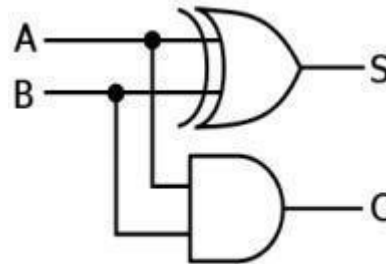

Figure 9: Half Adder Circuit

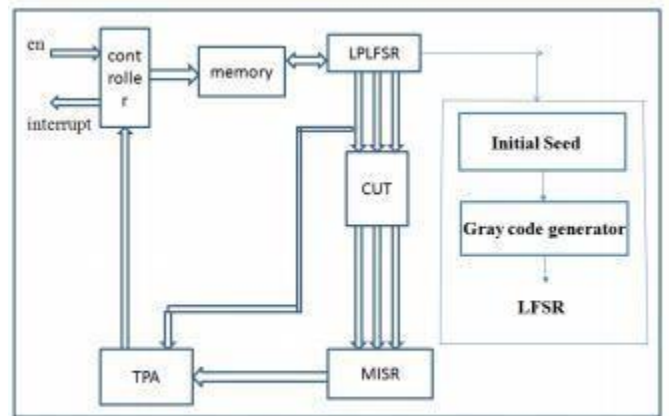

Figure 8: Low power ATPG system

It is similar to fig. 1 except LPLFSR block. Each block rather than low power LFSR of above methodology are explained in section II. The advantage of Gray code compared to the binary code is it has only one bit which changes for each step that means it has less switching activity so that the power consumption is less. This will be useful in the circuits which are sensitive to the glitches or noise. This proposed methodology reduces power and delay up to 55% and 6% respectively.

4. PROPOSED METHOD APPLIED TO HALF ADDER

This proposed method is implemented in Half Adder to verify its functionality. Firstly the Half Adder is designed using verilog code in Xilinx after that its functionality is checked using proposed method. In Low Power LFSR methodology the Half Adder is taken as CUT.

This Half Adder is instantiated into CUT. The CUT takes the output of LFSR as the input and generates the CUT output. If LFSR has 10 bits then first 5 MSB bits are taken as A input and second 5 LSB bits as B input. After getting CUT output as Sum and Carry they are combined as 10 bits which are inputs to the MISR. Next the output patterns MISR are generated. The TPA compares LFSR & MISR patterns and gives the output as interrupt. If the interrupt is generated as „0“ then the CUT is faulty

circuit, otherwise CUT is fault free

circuit. The power consumption and delay both are reduced up to 58% and 8% respectively due to less switching activity in Gray code patterns.

**5. PROPOSED METHOD APPLIED TO FIR FILTER**

This proposed method is implemented in FIR Filter to verify its functionality. Firstly the Half Adder is designed using verilog code in Xilinx after that its functionality is checked using proposed method. In Low Power LFSR methodology the FIR Filter is taken as CUT.

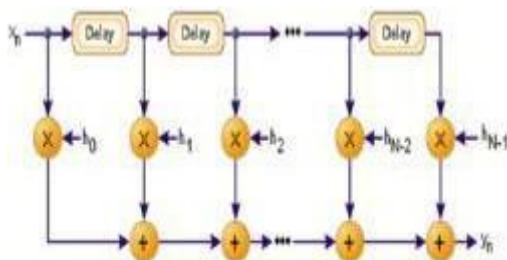

Figure 10: FIR Filter Circuit

This FIR Filter is instantiated into CUT. The CUT takes the output of LFSR as the input and generates the CUT output. The coefficients for FIR filter are generated using Matlab software. In this paper Low pass filter is used whose order is 5, cut-off frequency is  $0.5 \cdot \pi$  and uses blackman window to generate coefficients. The coefficients generated are 0.0000, 0.1083, 0.5000, 0.1081 and 0.0000. These coefficients are used to design Low Pass FIR filter. The power consumption & delay both are reduced due to less switching activity in Gray code patterns.

**6. SIMULATION AND SYNTHESIS RESULTS**

The proposed method is simulated and synthesized using verilog HDL on Xilinx 14.7. The simulation results are shown below and the synthesis reports are explained in below tables.



(a) Top module output of Existing method which shows circuit is fault free.



(b) Top module output of Existing method which shows circuit is faulty.



(c) Top module output of proposed method which shows circuit is fault free.

TABLE I

LOGIC UTILIZATION OF PROPOSED METHOD

Logic	Utilization
Number of slice registers	47
Number of slice Flip Flops	42
Number of 4 input LUTs	29
Number of bonded IOBs	25
Average fan-out of non-clock nets	2.76

POWER, DELAY AND POWER DELAY PRODUCT COMPARISON

Method	Power (W)	Delay (ns)	PDP (pJ)
ATPG using LFSR	0.034W	6.469ns	219.9pJ
ATPG using low power LFSR	0.015W	6.097ns	91.4pJ

## 7. CONCLUSION

In this paper a parallel test pattern methodology for shared memory multi-core environments is proposed using low power LFSR and it is implemented on Half Adder and FIR filter circuits to verify their functionality. This method enhances effective test patterns which are used for testing a device or circuit with less power consumption and delay. The proposed method is simulated and synthesized by using Xilinx 14.7. From the above values we can say that power consumption and delay are successfully reduced by 55% and 6% respectively. The comparison results shows that the proposed design with less power and delay can be good candidate and suitable for design automations with effective testing analysis. The future scope of this Low Power ATPG methodology is to reduce the

TABLE III

Method	Power (W)	Delay (ns)	PDP (pJ)
Half Adder using LFSR	0.082	7.051	578.1
Half Adder using low power LFSR	0.034	6.469	219.9

The comparison of FIR filter using existing and proposed methods is shown in Table IV.

TABLE IV

Method	Power (W)	Delay (ns)	PDP (pJ)
FIR filter using LFSR	0.082	7.051	578.1
FIR filter using low power LFSR	0.034	6.469	219.9

delay by which the time for generating the pseudo random test sequences can be increased.

## ACKNOWLEDGEMENT

We hereby wishing thank you for our management for providing good facilities in labs

## REFERENCES

- [1] S. Patil and P. Banerjee, "Fault partitioning issues in an integrated parallel test generation/fault simulation environment,"
- [2] X. Cai, P. Wohl, J.A. Waicukauski and P. Notiyath "Highly efficient parallel ATPG based on shared memory,"
- [3] K-W. Yeh, J-L. Huang, H-J. Chao and L-T. Wang "A circular pipeline processing based deterministic parallel test pattern generator,"