

RFID Based Vehicle Emission Detection Using Wireless Sensor Network

Sowmya S¹, Anita Kumari², Darshini M.S³, Jeevitha R⁴, Lavanya S⁵

¹Assistant professor, Department of Computer Science and Engineering,
ATME College, 13th Kilometer Bannur Road Mysuru 570028, Karnataka

^{2,3,4,5} Department of Computer Science,
ATME College, 13th Kilometer Bannur Road Mysuru 570028, Karnataka

Email: sowmya.atme@gmail.com¹, akanitakumari10@gmail.com²,
darshnini3095@gmail.com³, jeevitha254153@gmail.com⁴,
lavanyasonessh77@gmail.com⁵

Abstract- The main objective of this paper is to monitor and control air pollution on roads. Vehicles while focusing to be one of the fastest technology, affecting life's on the other way. In this system, Radio frequency identification (RFID) technology being low-cost and mature wireless communication method, adopted to collect and monitor emissions rate by vehicles. RFID devices need to be installed on the traffic lights so that reliable emission rate can be interrogated when the vehicles stop in front of the red light. By applying this system, our aim is to realize green traffic network.

Index Terms- Radio frequency identification, Smoke sensor, Microcontroller, GSM

1. INTRODUCTION

In today's fastest world we want to reach our destination as fast as possible. Though we have public transports for this purpose, we find it time consuming and costly. The goal of introducing public transports was to provide people with safe and pollution free environment [1]. 20 people in a vehicle better than one vehicle per user. There is number of on roads vehicles so it very difficult to force each vehicle for testing [2]. It focuses on traffic free environment, cheap, ecofriendly, safe etc. Air pollution from vehicles has become the main cause for respiratory diseases and asthma attacks. Study shows that 70% of the total air pollution, caused from polluting gases released by vehicles. In order to control the air pollution, the amount of air pollution needs to be monitored and vehicles responsible for polluting should be identified. In this paper we are monitoring carbon emissions by moving vehicles. Looking towards recent situation of Volkswagen, where 11 millions of vehicles were equipped with software that used to cheat on emission tests. Wireless Sensor Networks (WSNS) have gained increased attention in traffic detection and avoiding road congestion. Radio frequency identification (RFID) technology is of low-cost and mature wireless communication method in order to identify, store and retrieve information when needed.

2. LITERATURE SURVEY

Wireless Sensor Networks have been used for surveying in various fields:

Smart waste management using wireless sensor network

As in many places we find that garbage bins are not cleaned at proper time intervals which results in hygienic problems, land pollution and ultimately leads to ugliness of that place. System is required not only to manage the status of garbage bins but also to provide information to the concerned authorities to manage the collection intervals, for cleaning the bins. This paper is in the form of 3 tier waste management system-intelligent

- Bin
- Gateway
- Remote base station

The parameters of the bin monitored are transmitted through a gateway to remote base station to be stored in database.

Smart parking system based on embedded system using sensor network

During the peak hours, locating a parking space in central city areas, is cumbersome for drivers. Reservation-based Smart Parking System (RSPS) that permits drivers to effectively locate and withhold the vacant parking spaces in mentioned. Cluster based algorithm helps in periodically learning the parking status from the sensor networks deployed in parking spaces, the reservation service is influenced by the change of parking status. The system monitors availability of idle parking slots and guides the vehicle to the nearest parking slot.

A survey on urban traffic management system using wireless sensor network

Wireless sensor networks (WSNS) have gained increased attention in traffic detection and avoiding

road congestion. This paper presents a survey of current urban traffic management schemes for priority based signaling and reducing congestion and AWT of vehicles.

3. REQUIREMENTS

- Smoke sensor
- Microcontroller
- RFID
- GSM

4. COMPONENT DESCRIPTION

4.1. Smoke sensor

MQ-2 gas sensor is composed by micro AL₂O₃ ceramic tube, Tin Dioxide (SnO₂) sensitive layer, measuring electrode and heater are fixed into a crust made by plastic and stainless steel net. The heater provides necessary work conditions for working of sensitive components. The enveloped MQ-2 has 6 pin, four of them are used to fetch signals, and other two are used for providing heating current.

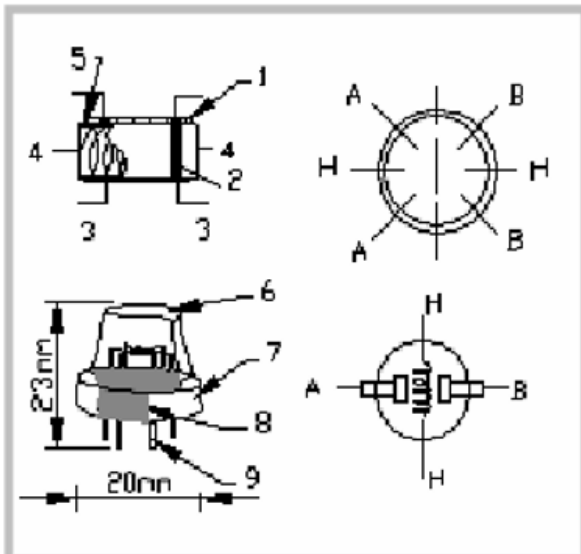

Fig. 1. Structure and configuration of mq-2 gas sensor

Standard measuring circuit of MQ-2 sensitive components consists of 2 parts. One is heating circuit having time control function (the high voltage and the low voltage work circularly). The second is the signal output circuit; it can accurately respond changes of surface resistance of the sensor.



Fig. 2. MQ2 Smoke Sensor

4.2. Microcontroller

We have used here general-purpose register: 8 bits × 32 registers (8 bits × 8 registers × 4 banks), ROM: 512 KB, RAM: 32 KB, Data flash memory: 8 KB, On-chip high-speed on-chip oscillator, On-chip single-power-supply flash memory.

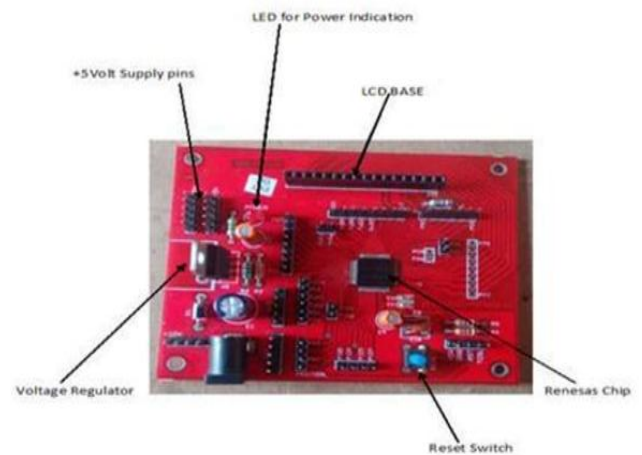

Fig. 3. 64 Pin Renesas Microcontroller Board

4.3. RFID

Radio-frequency identification (RFID) is an automatic identification method, relying on storing and remotely retrieving data using devices called RFID tags or transponders. The technology requires some extent of cooperation of an RFID reader and an RFID tag.

A basic RFID system consists of three components an antenna or coil, a transceiver (with decoder), a transponder (RFID tag). RFID tags are electronically programmed with unique information. An RFID tag is comprised of a microchip containing identifying information and an antenna that transmits this data wirelessly to a reader.



Fig. 4. A RFID Tag



Fig .5. RFID Reader

4.4. GSM

Global system for mobile communication (GSM) is a globally accepted standard for digital cellular communication. GSM is the name of a standardization group established in 1982 to create a common European mobile telephone standard that would formulate specifications for a pan European mobile cellular radio system operating at 900 MHz. It is estimated that many countries outside of Europe will join the GSM partnership.



Fig. 6. GSM

5. EXISTING SYSTEM

With the increasing number of automobiles, especially in some metropolis, such as Europe and America, it is very impending to resolve the problem of air pollution resulting from automobile exhaust gas. In Europe, air pollution has reached levels judged as hazardous to human health. To fight this problem, the motor

emissions standards have been established and Fig. 7.

Block Diagram

promoted in many developed countries for many years. Furthermore, some improved measures in vehicle engines or the quality of gasoline have also been developed by researchers. However, these methods seem not to solve radically the emissions pollution problems. The motor emissions standard is very difficult to implement in real-life. Although government forces all cars for testing or examining periodically as the local standard, the actual vehicle on-road emissions are usually much higher than those which are measured during the emission inspections.

6. PROPOSED SYSTEM

The active RFID and the active RFID tag are designed to collect the emissions data from the vehicle exhaust system. RFID reader will receive emissions data when the vehicles which are installed on RFID tag drive into inspect range. However, most traffic lights in a city are just connected and controlled for shifting signals which do not provide the capability of data transmission.

7. DETAILED DESCRIPTION

The implementation of the system has been described below:

7.1. Block diagram

The blocks in the diagram depict the major components of the system and their interconnections.

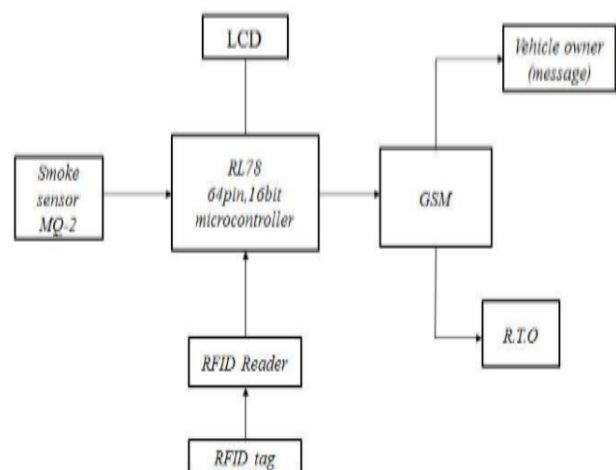

Fig. 7. Block Diagram

7.2. Flow chart

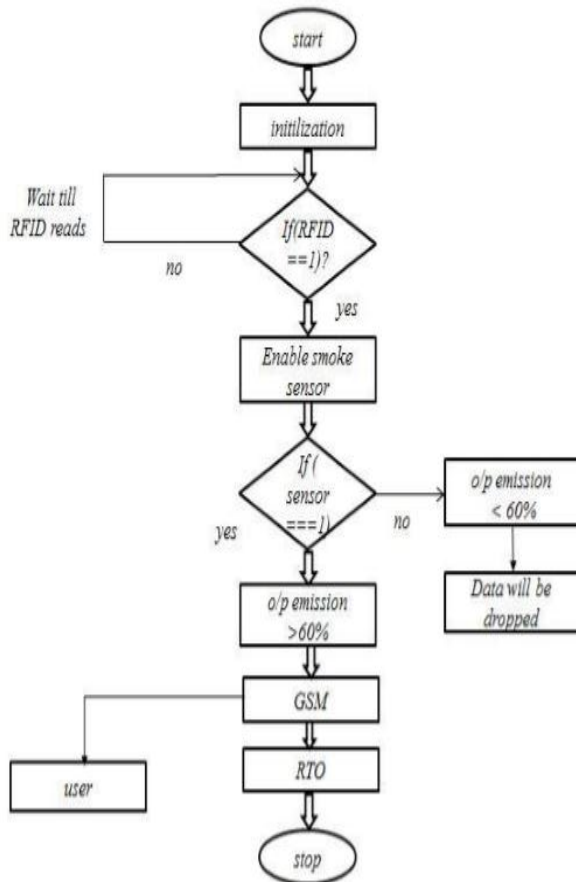

Fig. 8. Flow Chart

7.3. Implementation Methodology

7.3.1. Hardware Requirements

- Microcontroller-32 bit RL78
- Power Supply
- Smoke Sensor
- RFID Tag
- RFID Reader
- GSM

7.3.2. Software Requirements

- Renesas flash programmer
- .net
- MySQL
- Cube suite
- Java
- Embedded programming

7.4. Advantages

- Green environment can be created in the city.
- To reduce the human inspection.

8. HARDWARE IMPLEMENTATION

8.1. Working

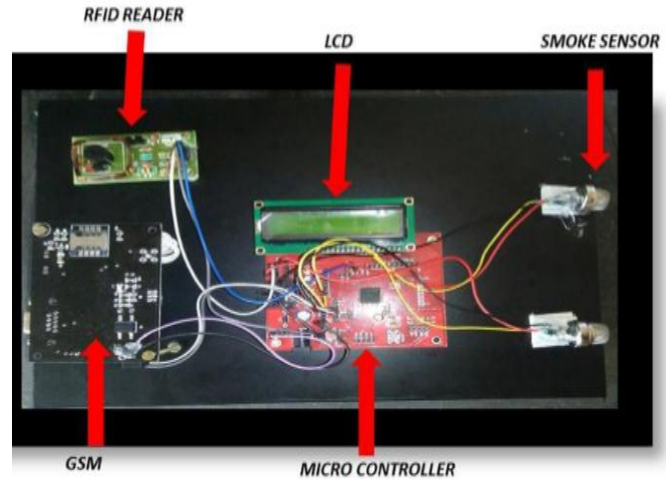

Fig. 9. Prototype for vehicle emission detection

The RFID tag is attached to vehicle that is identified by RFID reader when the vehicle stops in front of red signal. Both reader and tag get communicated by RF signal. Reader generates the carrier signal send out through antenna. Generated carrier signal hits the tag. Tag receives, modifies the carrier signal, send back into a modulated signal to a receiver. Reader antenna receives the modulated signal and, sends them to the reader. Reader decodes the data. Smoke sensor which is present in vehicle senses emission value in analog form. Analog to digital convertor converts this analog value into digital form and send the output to microcontroller. In microcontroller, if emission rate is above 60%, message is sent to R.T.O otherwise dropped. R.T.O receives message through G.S.M. R.T.O also informs the vehicle owner by sending "HIGH EMISSION" message and emission test need to be done.

8.2. Experimental Results

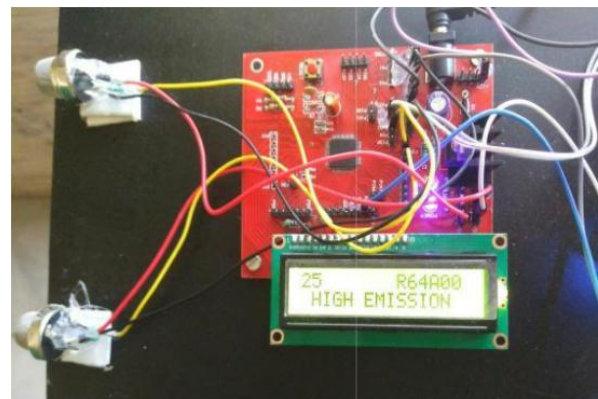

Fig. 10. RFID Based Emission Detection Using GSM

9. CONSLUSIONS

RFID technology, as one of the enabling technologies, is employed to develop the information system. RFID reading can be interrogated along with the corresponding tag ID through a wireless connection among traffic lights and vehicles. This will maintain the database and graph for the data by monitoring the emissions data, the engine health can be easily inspected and examined.

10. FUTURE SCOPE

Vehicles can provided with emission rate display inside car with 3 days after deadline date when stops at red light. Alcohol detection sensor can also be installed in vehicles that automatically detects amount of alcohol consumption by driver.

REFERENCES

- [1]. Bengt Johansson, "Will new technology be sufficient to solve the problem of air pollution caused by Swedish road transport?," *Transport Policy*, Vol. 5, pp. 213-221, October 1998.
- [2]. Journal on intelligent traffic signal control system using embedded system by innovative systems design and engineering ISSN 2222-1727(paper) ISSN 2222-2871(online)
- [3]. D.P. Chock, S.L. Winkler, T.Y. Chang, S.J. Rudy, and Z.K. Shen, "Urban ozone air quality impact of emissions from vehicles using reformulated gasolines and M85", *Atmospheric Environment*, Vol. 28, pp. 2777-2787, September 1994
- [4]. D.S Eisinger, "Evaluating inspection and maintenance programs: A policy-making framework," *journal of the air and waste management association*, vol.55, pp.147-162, feb 2005.
- [5]. T. LEELARAM M, "RFID Based Vehicle Emissions in Cities on Internet of Things", *SRM University, Kattankulathur, Chennai*, Vol. 3, Issue: 2, Feb.-March. : 2015

Author's Profile



B.E in CSE from Computer Science and Engineering, Karnataka, India



B.E in CSE from Computer Science and Engineering, Karnataka, India



B.E in CSE from Computer Science and Engineering, Karnataka, India



B.E in CSE from Computer Science and Engineering, Karnataka, India